

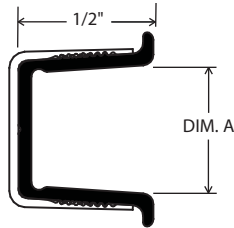

PRODUCT DETAIL :



USAGE

Fry Reglet “Snap-In” Reveal is used with moldings shown in chart below to provide a different finish detail. The lip on the “Snap-In” Reveal covers wall covering edges and prevents peeling. “Snap-In” reveal is designed for use on walls and should not be applied to ceilings.

GUIDE SPECIFICATION

Where indicated on drawings, Fry Reglet “Snap-In” Reveal, as manufactured by Fry Reglet Corporation, shall be installed. Aluminum shall be extruded alloy 6063 T5, with clear anodized finish, unless otherwise specified.

“SNAP-IN” REVEAL SIZE

DIM. A - REVEAL WIDTH	NUMBER
3/8**	DRM-SNAP-IN-375
1/2***	DRM-SNAP-IN-50
5/8****	DRM-SNAP-IN-625

*Snap-In fits following profiles:
DRM-50-50, DRM-625-50, DRMF-50-50, DRMF-625-50

**Snap-In fits following profiles:
DRM-50-625, DRM-625-625, DRMF-50-625, DRMF-625-625

***Snap-In fits following profiles:
DRM-50-75, DRM-625-75, DRMF-50-75, DRMF-625-75

INSTALLATION DETAIL : Cross Section

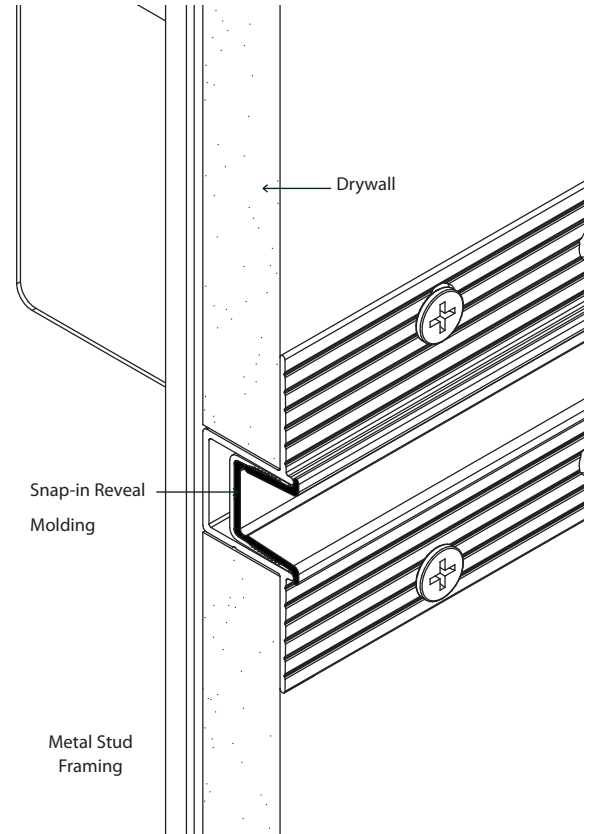
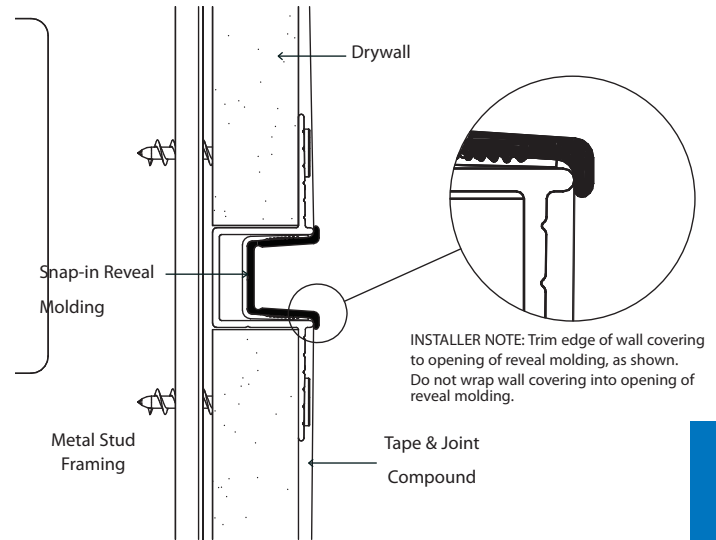

DRYWALL